



TWIN-PARQUET

Experience the nature at home.



MANUFACTURED IN NORTH GERMANY





In today's Time, we prioritize different things when it comes to living than we did ten or even twenty years ago. Sustainability and closeness to nature are in focus, as well as the use of high-quality raw materials and a preference for locally sourced products. At the same time, we also desire a lot of individuality and creative expression for our living style.

With GlanPark® Twin-Parquet, you can meet all these demands - uncompromisingly and completely authentic. Sustainability and closeness to nature are ensured by the use of sustainable and high-quality raw materials as well as environmentally-friendly stains and oils from Rubio® Monocoat. Production takes place in our Lüneburg parquet factory in the north of Germany and is done by hand, supported by modern production facilities.

In terms of individual and creative design, you can unfold yourself almost limitlessly because you alone create your dream floor from the Twin-Parquet, in which you determine the individual components such as format, sorting, surface structure, effect, and color.

FROM MANY BUILDING BLOCKS, YOU CREATE YOUR PERFECT OVERALL PICTURE.

We produce your Twin-Parquet exactly according to your specifications. Only when you have chosen all the individual components and combined them to create your desired parquet, our employees in the factory start with the production.

No floor is the same as another in its entirety, no plank has a doppelgänger – rooms can hardly be designed more individually than with the choice of a Twin-Parquet floor. You create a healthy living environment and a characterful base to fulfill your personal living dreams for many years to come.



Rubio MONOCOAT



HAUKE



ASTRID



OLE



NEELE



SVANTJE



MICHEL



FRAUKE



THIES



GLANWOOD L

Glanwood | rustikal sorting | raw parquet

Glanwood L | 16 mm

1800–2400 mm (10 % Shorter lengths possible)
approx. 16 mm | **± 3/4 mm top layer** | approx. 12 mm plywood carrier (birch)
beveled edges 2V | tongue and groove

Assortment: especially rustic surface with depth and structure

HxBxL 16 x 180 x 1800–2400 mm*

**Availability on request, delivery time of 4–6 weeks possible*

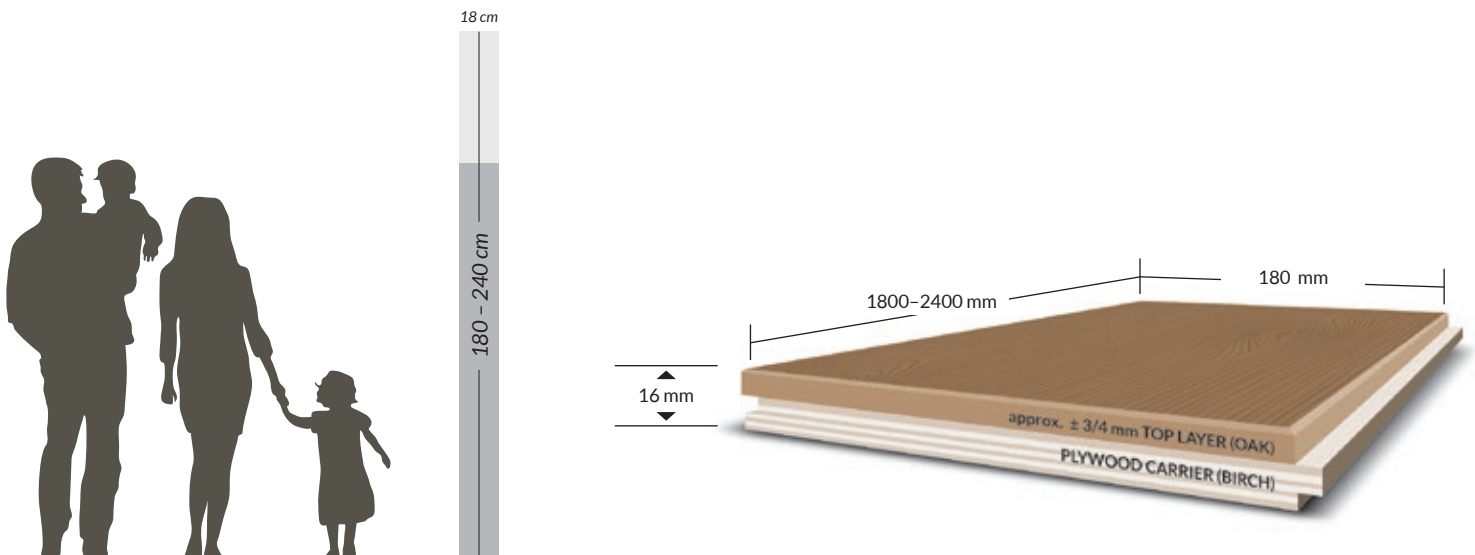

Thickness approx. 16 mm

Shorter lengths are possible upon request. Due to the different formats, variations between the ordered and the final product may occur. This slight excess material is a maximum of 3% and will be invoiced.



**5 YEARS
WARRANTY**



**SUITABLE FOR
UNDERFLOOR
HEATING**



**SUITABLE FOR
UNDERFLOOR
COOLING**



GLANWOOD XL



Glanwood | color oil Svantje

Glanwood XL | 16 mm

1800–2400 mm (10 % shorter lengths possible)
approx. 16 mm | $\pm 3/4$ mm top layer | approx. 12 mm plywood carrier (birch)
Beveled edges 2V | tongue and groove

Assortment: especially rustic surface with depth and structure

HxBxL 16 x 220 x 1800–2400 mm*

**Delivery time of 10–20 days possible*

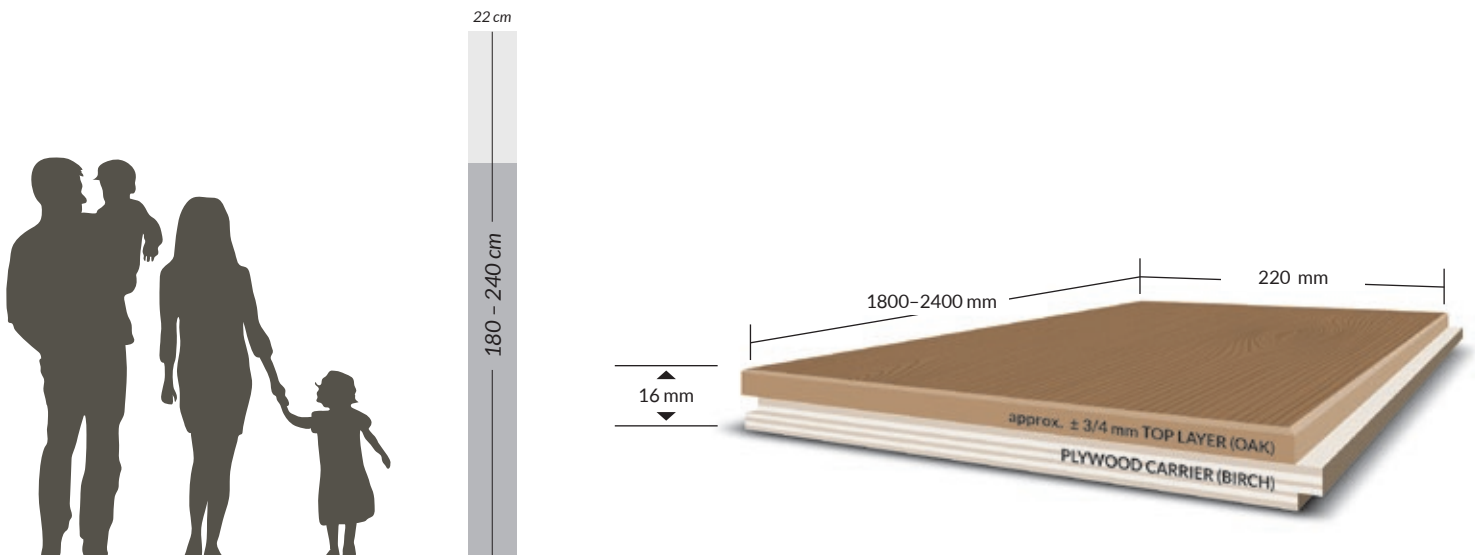

Thickness approx. 16 mm

Shorter lengths are possible upon request. Due to the different formats, variations between the ordered and the final product may occur. This slight excess material is a maximum of 3% and will be invoiced.



**5 YEARS
WARRANTY**



**SUITABLE FOR
UNDERFLOOR
HEATING**



**SUITABLE FOR
UNDERFLOOR
COOLING**



GLANWOOD STRIP



Glanwood solid wood parquet | rustikal sorting | raw parquet

Glanwood solid wood parquet | Herringbone 90° | 16 mm

600 | 700 mm

approx. 16 mm | approx. **4 mm top layer** of European oak (deep cracks filled) | approx. 12 mm plywood carrier (birch)
unfinished | tongue and groove

Assortment: especially rustic surface with depth and structure

HxBxL 16 x 120 x 600 mm*

HxBxL 16 x 140 x 700 mm*

**Delivery time of 10–20 days possible*

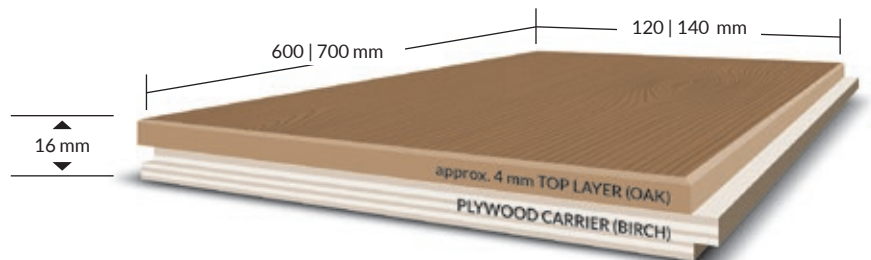

Thickness approx. 16 mm

Herringbone and Hungarian pattern are supplied in the above dimensions with left and right elements.



**5 YEARS
WARRANTY**



**SUITABLE FOR
UNDERFLOOR
HEATING**



**SUITABLE FOR
UNDERFLOOR
COOLING**



TWIN-PARQUET 10



Twin-Parquet | elegant sorting

Surface illustrations: Raw material without surface treatment

10 mm sanded/filled

1800–2400 mm (10 % shorter lengths possible)

approx. 10 mm | ca. **4 mm top layer** (oak veneer) | approx. 6 mm plywood carrier (birch)

Quality according to factory standards | produced analogously to DIN EN 13489 | Wood moisture approx. 9 %

Beveled edges 2V or 4V | tongue and groove

Available assortments: elegant, natural, markant and rustic

HxBxL 10/4 x 180 x 1800–2400 mm*

*Delivery time of 10–20 days possible

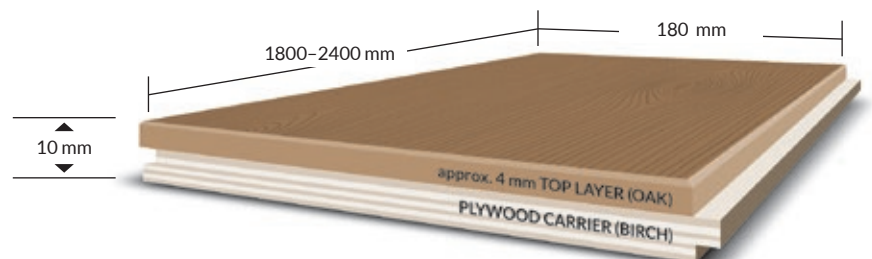
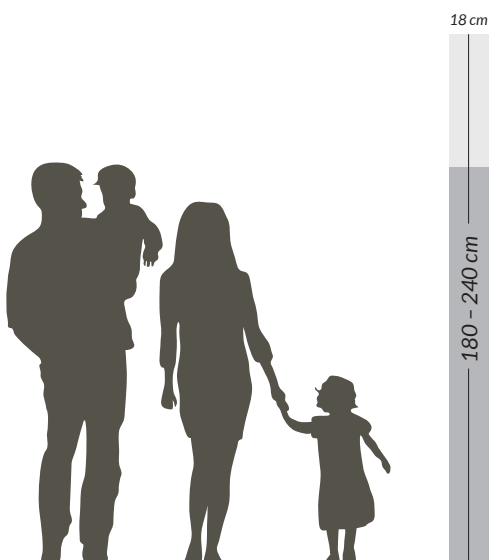

Thickness approx. 10 mm

Shorter lengths are possible upon request. Due to the different formats, variations between the ordered and the final product may occur. This slight excess material is a maximum of 3% and will be invoiced.



**5 YEARS
WARRANTY**



**SUITABLE FOR
UNDERFLOOR
HEATING**



**SUITABLE FOR
UNDERFLOOR
COOLING**



TWIN-PARQUET 13



Twin-Parquet | natural sorting

Surface illustrations: Raw material without surface treatment

13 mm sanded/filled

1800–2400 mm (10 % shorter lengths possible)

approx. 13 mm | approx. **4 mm top layer** (oak veneer) | ca. 9 mm plywood carrier (birch)

Quality according to factory standards | produced analogously to DIN EN 13489 | Wood moisture approx. 9 %

Beveled edges 2V or 4V | tongue and groove

Available assortments: elegant, natural, markant and rustic

H x B x L 13/4 x 140 x 1800–2400 mm*

H x B x L 13/4 x 220 x 1800–2400 mm*

H x B x L 13/4 x 180 x 1800–2400 mm*

H x B x L 13/4 x 260 x 1800–2400 mm*

*Delivery time of 10–20 days possible

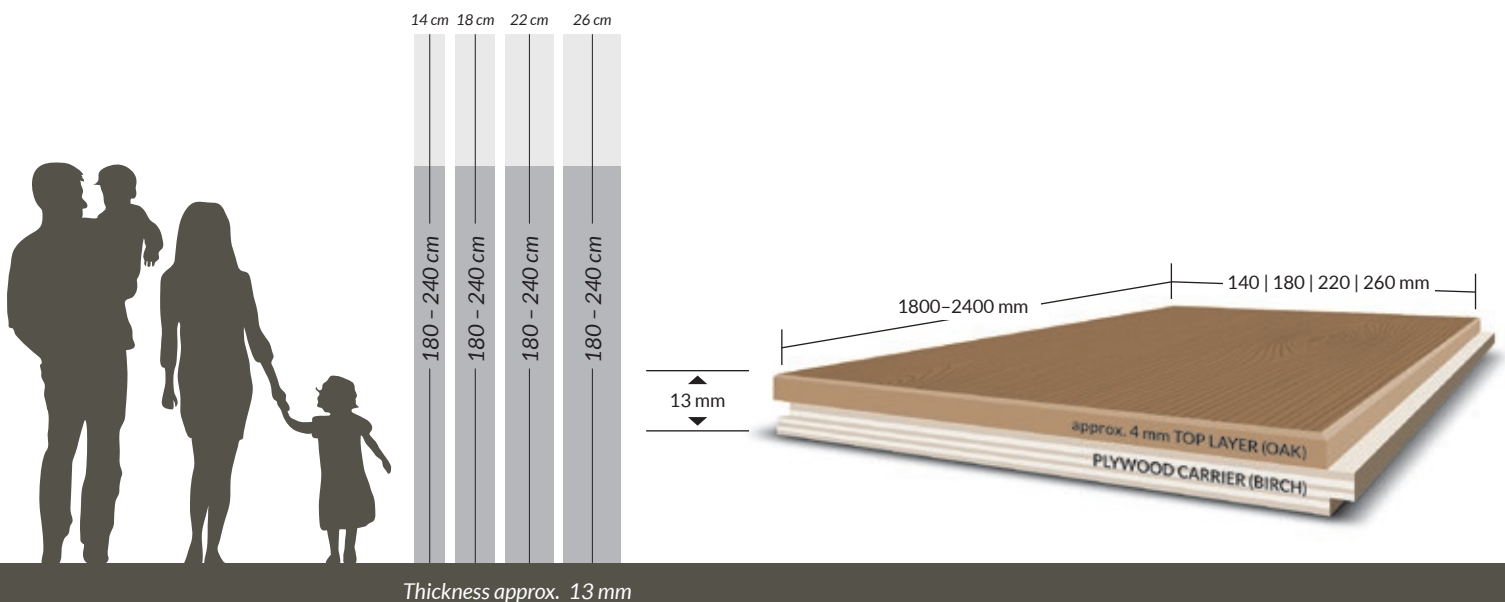

Shorter lengths are possible upon request. Due to the different formats, variations between the ordered and the final product may occur. This slight excess material is a maximum of 3 % and will be invoiced.





TWIN-PARQUET 18



Twin-Parquet | striking sorting

Surface illustrations: Raw material without surface treatment

18 mm sanded/filled

1800–2400 mm (10 % shorter lengths possible)

approx. 18 mm | approx. **6 mm top layer** (oak veneer) | approx. 12 mm plywood carrier (birch)

Quality according to factory standards | produced analogously to DIN EN 13489 | Wood moisture approx. 9 %

Beveled edges 2V or 4V | tongue and groove

Available assortments: elegant, natural, markant and rustic

HxBxL 18/6 x 140 x 1800–2400 mm*

HxBxL 18/6 x 180 x 1800–2400 mm*

HxBxL 18/6 x 220 x 1800–2400 mm*

*Delivery time of 10–20 days possible

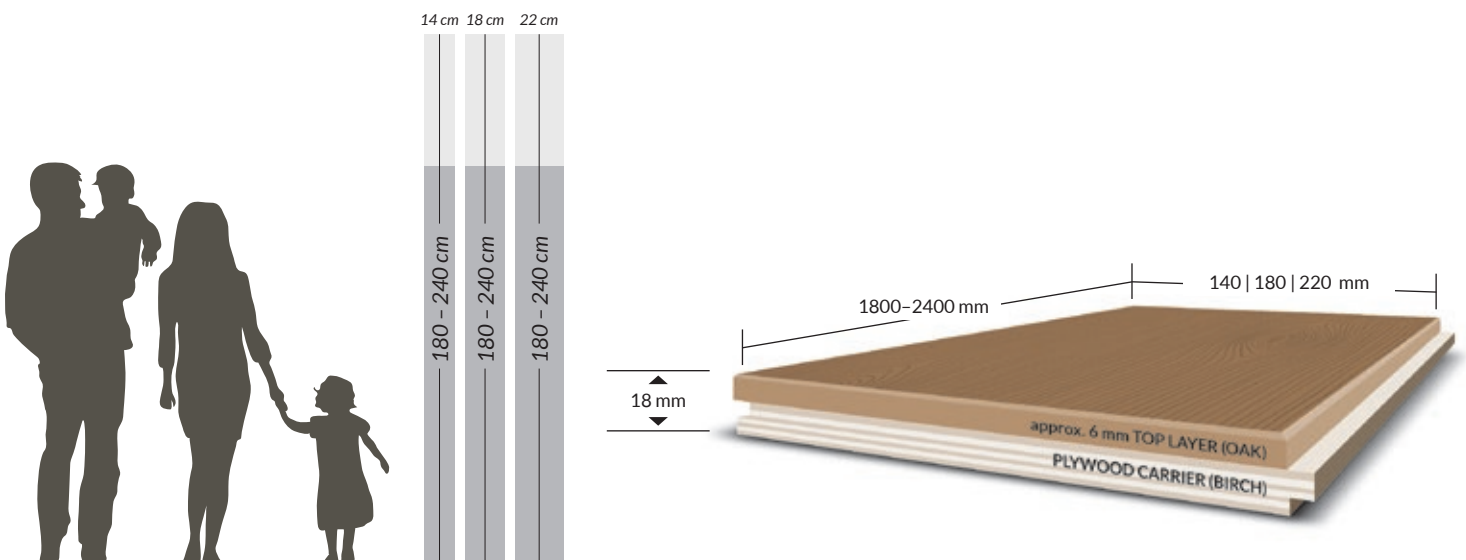

Thickness approx. 18 mm

Shorter lengths are possible upon request. Due to the different formats, variations between the ordered and the final product may occur. This slight excess material is a maximum of 3% and will be invoiced.



**5 YEARS
WARRANTY**



**SUITABLE FOR
UNDERFLOOR
HEATING**



**SUITABLE FOR
UNDERFLOOR
COOLING**



TWIN-MAXI-STRIP

Strip | Herringbone 90°



Twin-Maxi-Strip | natural sorting

Striking sorting

Rustic sorting

Surface illustrations: Raw material without surface treatment

10 mm sanded/filled

approx. 10 mm | approx. **4 mm top layer** (oak veneer) | approx. 6 mm plywood carrier (birch)

Quality according to factory standards | produced analogously to DIN EN 13489 | Wood moisture approx. 9 %

Beveled edges 4V | tongue and groove

Available Assortments: natural, markant and rustic

HxBxL 10/4 x 180 x 900 mm

*Delivery time of 10-20 days possible

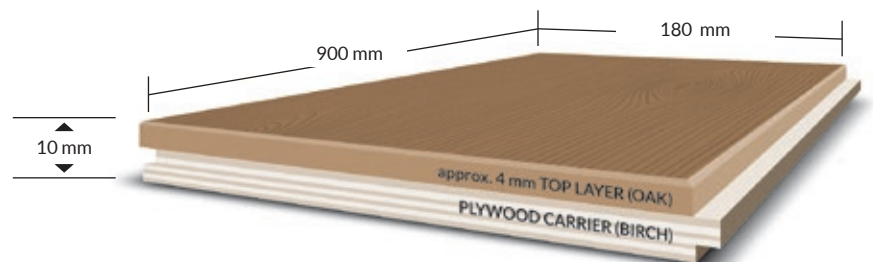

Thickness approx. 10 mm

Herringbone and Hungarian pattern are supplied in the above dimensions with left and right elements.



**5 YEARS
WARRANTY**



**SUITABLE FOR
UNDERFLOOR
HEATING**



**SUITABLE FOR
UNDERFLOOR
COOLING**



TWIN-STRIP PARQUET

Strip | Herringbone 90°



Twin-Strip-Parquet | elegant/natural sorting



Striking/rustic sorting

Surface illustrations: Raw material without surface treatment

10 mm sanded/filled

approx. 10 mm | ca. **4 mm top layer** (Eiche) | approx. 6 mm plywood carrier (birch)

approx. 13 mm | ca. **4 mm top layer** (Eiche) | approx. 9 mm plywood carrier (birch)

approx. 16 mm | ca. **4 mm top layer** (Eiche) | approx. 12 mm plywood carrier (birch)

Quality according to factory standards | produced analogously to DIN EN 13489 | Wood moisture approx. 9 %

Beveled edges 4V | tongue and groove

Available Assortments: elegant/natural, markant/rustic

HxBxL 10/4 x 120 x 600 mm

HxBxL 13/4 x 120 x 600 mm°

HxBxL 16/4 x 120 x 600 mm°

HxBxL 10/4 x 140 x 700 mm

HxBxL 13/4 x 140 x 700 mm°

HxBxL 16/4 x 140 x 700 mm°

*Delivery time of 10-20 days possible

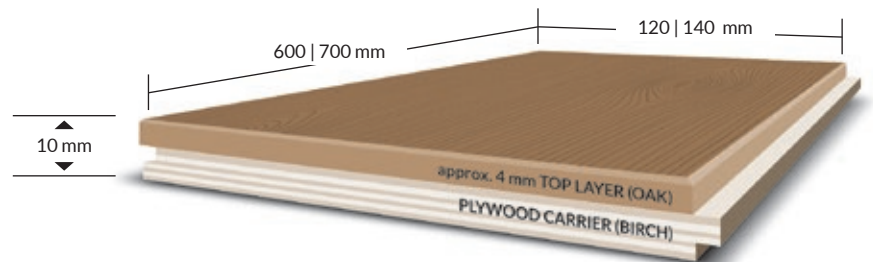
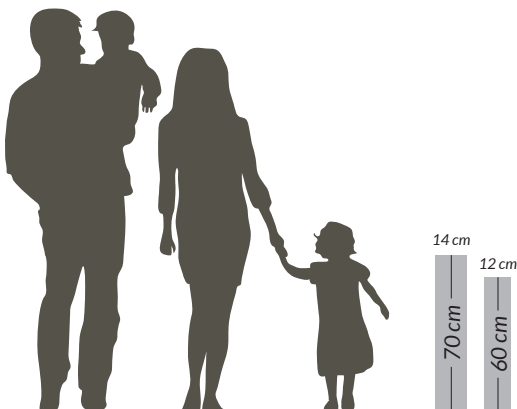

Thickness approx. 10 | 13 | 16 mm

Herringbone and Hungarian pattern are supplied in the above dimensions with left and right elements.



5 YEARS WARRANTY



SUITABLE FOR UNDERFLOOR HEATING



SUITABLE FOR UNDERFLOOR COOLING



TREAD EDGES

Twin-Parkett Block steps | Angled steps



Staircase illustration only exemplary

BLOCK STEP 13 mm sanded/filled

Dimensions: 40 x 1800 mm

Riser:: 25 mm

approx. 13 mm | approx. **4 mm top layer** (oak)

approx. 9 mm plywood carrier (birch)

tongue and groove

HxBxL 13/4 x 40 x 1800 mm

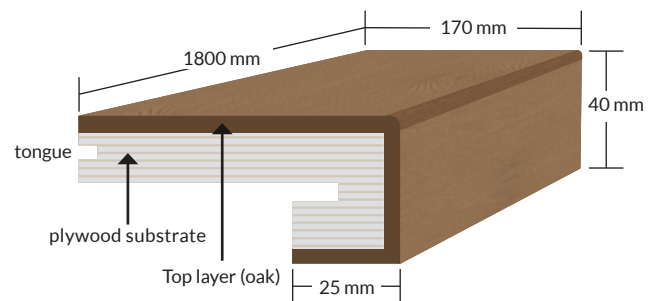

ANGLED STEP 13 mm sanded/filled

Dimensions: 210/210 x 1800 mm

approx 13 mm | approx **4 mm top layer** (oak)

approx 9 mm plywood carrier (birch)

tongue and groove

HxBxL 13/4 x 210/210 x 1800 mm

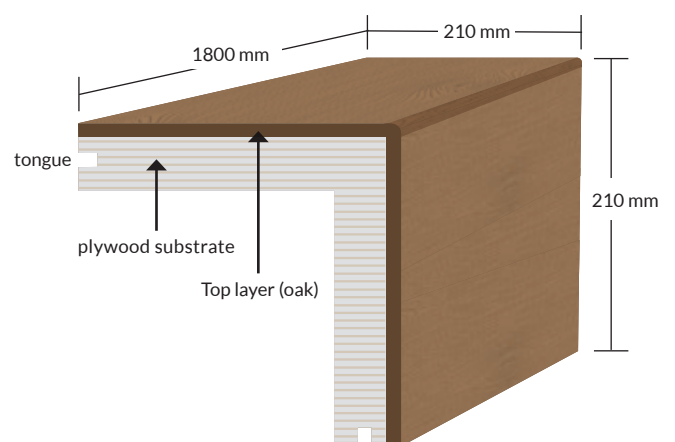

5 YEARS
WARRANTY

FOUR SORTINGS

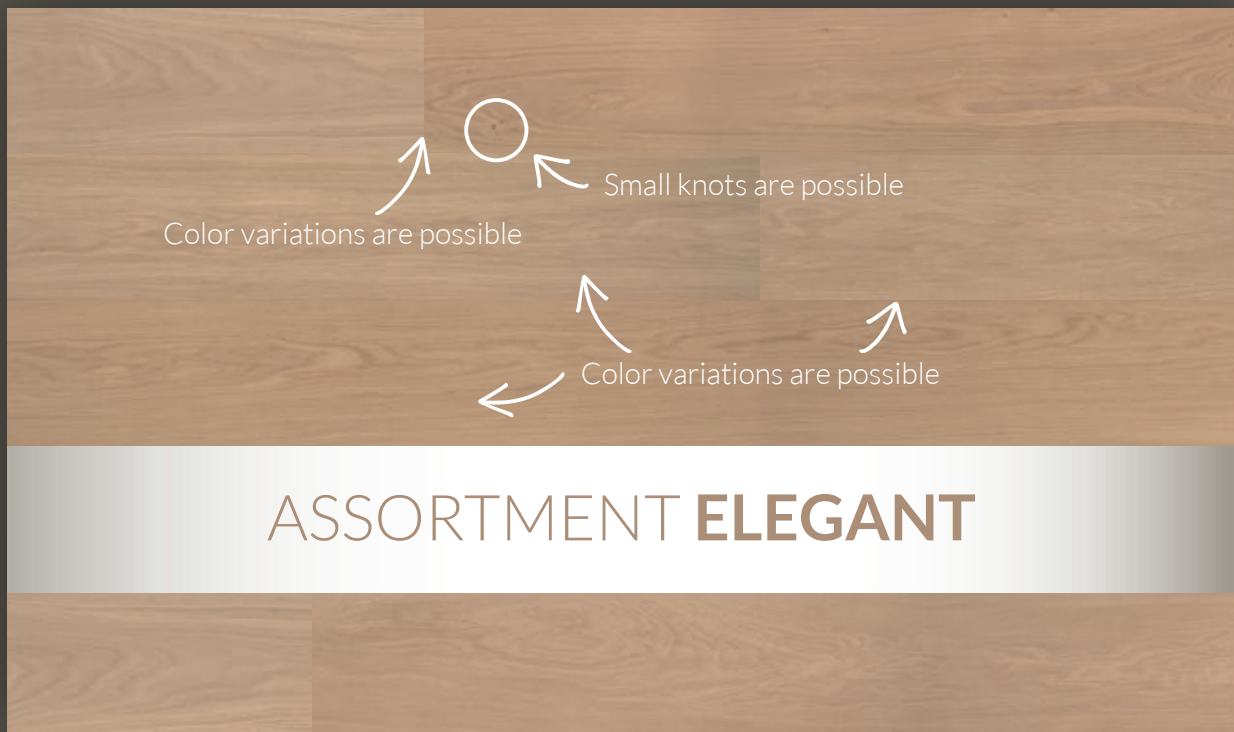

Illustrations: raw material without surface treatment

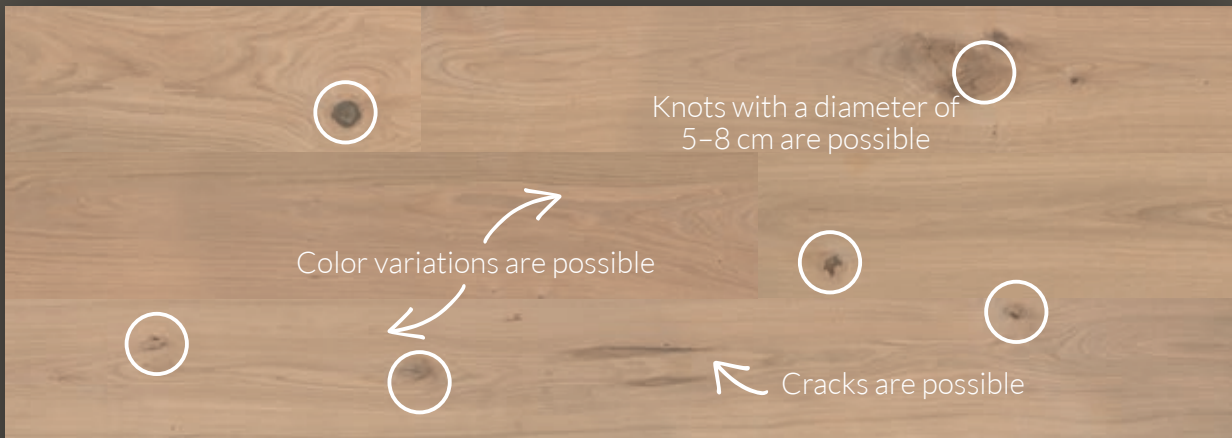

ASSORTMENT **MARKANT**

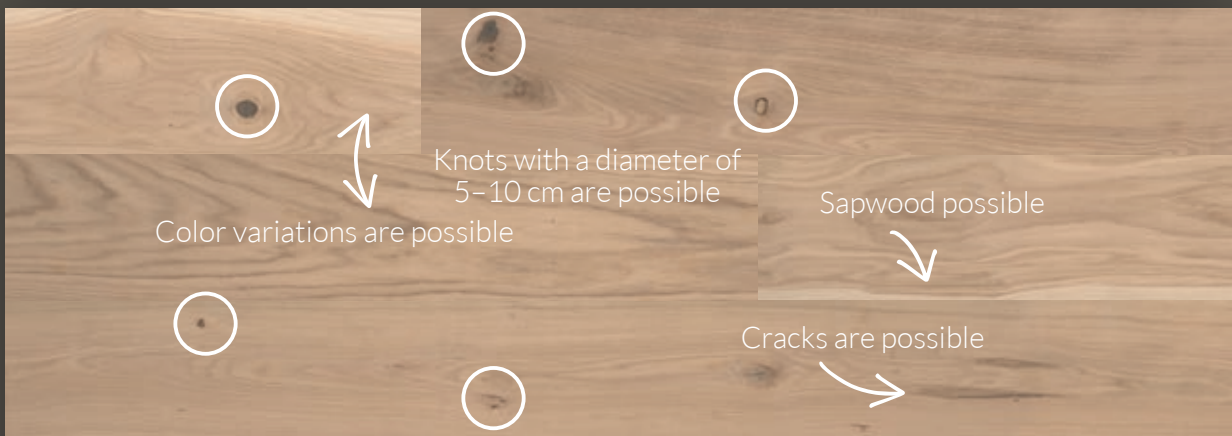

ASSORTMENT **RUSTIC**



Wood is a natural product - variations from the sorting guidelines listed may occur and do not constitute a defect.





Wood is a natural product - variations from the sorting guidelines listed may occur and do not constitute a defect.



Installation example: Elegant sorting | Cotton White colored oil



Wood is a natural product - variations from the sorting guidelines listed may occur and do not constitute a defect.



Installation example: Natural sorting | Pure colored oil



! Wood is a natural product - variations from the sorting guidelines listed may occur and do not constitute a defect.



Installation example: Markant sorting | Chocolate colored oil



! Wood is a natural product - variations from the sorting guidelines listed may occur and do not constitute a defect.



Installation example: Rustical sorting | White 5 % colored oil



*The right choice
from the beginning.*

SIX SURFACES



**FINE
SANDED.**



**LIGHTLY
BRUSHED.**



**MEDIUM
BRUSHED.**



**HEAVILY
BRUSHED.**



**OPTIK
HAND-PLANED SURFACE.**

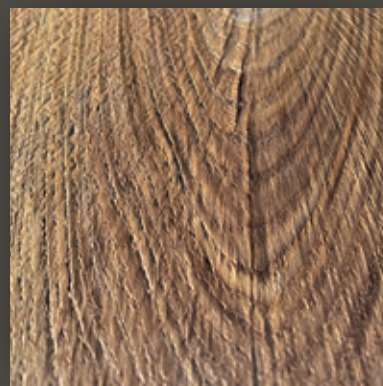

**OPTIK
SAWN SURFACE.**

The refreshing liveliness of the parquet is achieved through the surface you choose. Not only does it vary the appearance of the floor, but also the feeling that accompanies you with every step on it. The respective character is created by brushing with wire or nylon brushes. This highlights and emphasizes the grain patterns of individual woods. The individual processing makes each plank a unique piece.





*A floor that
tells stories.*

TWELVE EFFECTS



Fumed Intense



Fumed Pure



Fumed Light



Smoke Intense



Smoke Pure



Smoke Light



Authentic 1

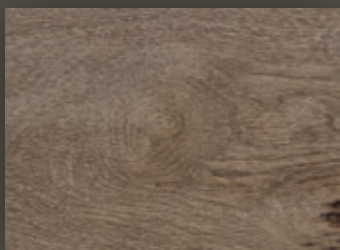

Authentic 2



Authentic 3



Authentic 4



Authentic 5



Authentic 6

The colors shown were applied to oak wood. The colors shown are indicative and not binding.

Rubio MONOCOAT

At GlanPark®-Parquet, we offer you versatile effects that give your desired floor its own unique character. By choosing a particular effect, you can skillfully adapt your parquet floor to your style and the ambiance of your living spaces, such as by selecting a smoking or aging effect. Here alone, you will find six different shades. Aging effects are also a selected means of giving the floor a lot of liveliness. We achieve these special effects through the use of a non-reactive pre-stain, which is applied simply and without overlap in our factory.





*Perfect in every
aspect of life.*

FORTY + 2 COLOURS



Antique Bronze



Aqua



Ash Grey



Biscuit



Black



Bourbon



Castle Brown

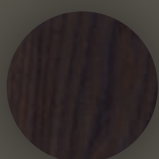

Charcoal



Cherry Coral



Chocolate



Corn silk



Cotton White



Dark Oak



Gris Beige



Havana



Ice Brown



Mahogany



Mist



Mist 5%



Mud Light



Natural



Oak



Olive



Oyster



Pine



Pure



Savanna



Silver Grey



Sky Grey



Slate Grey



Smoke



Smoke 5%



Smoked Oak



Stone



Super White



Titanium Grey



Vanilla



Walnut



White



White 5%



Crudo



Optics raw wood

The colors shown were applied to oak wood. The colors shown are indicative and not binding.

Rubio MONOCOAT

Trust your intuition and imagination when choosing the color tone. Colors are perceived individually and can be felt much better than defined. And a color that will surround and accompany you for many years over a large area should match your furnishings, style, and personal taste. Forty standard colors for GlanPark®-Parquet provide you with sufficient flexibility and decision-making space.





*In any case
The right decision.*

THIRTEEN COLOR TRENDS



Cinnamon Brown

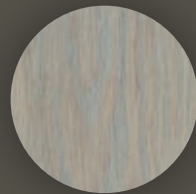

Nordic Blue

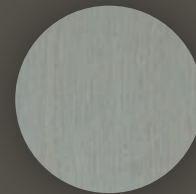

Morning Mist



Velvet Green



Touch of Gold



Peacock Green

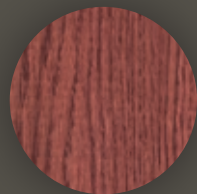

Rusty Brown



Midnight Indigo

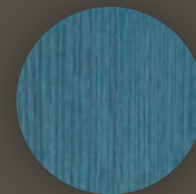

Teal Blue

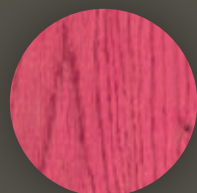

Pomegranate Pink



Winter Blush

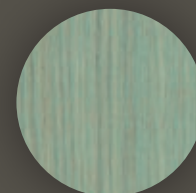

Frost Green

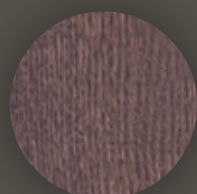

Heather Purple

Rubio MONOCOAT

The colors shown were applied to oak wood. The colors shown are indicative and not binding.

For stronger contrasts, more colorfulness and greater creative freedom when composing your GlanPark®-Parquet, you also have thirteen vibrant color trends at your disposal. This creates even more expressiveness and creativity in your flooring. The enormous variety of variations is made possible by the combination of previous effect treatment and final oil treatment.

A brand of
LPM GmbH

Zeppelinstraße 3
21337 Lüneburg

T +49 (0)4131 9276999

F +49 (0)4131 9276998

M info@glanpark.de

www.glanpark.de

 [@glanpark.parkett](https://www.facebook.com/glanpark.parkett)

 [@glanpark_parkett](https://www.instagram.com/glanpark_parkett)