



3-LAYER-PARQUET

Experience the nature at home.



WE MAKE LIVING DREAMS COME TRUE





Do you want a hardwood floor that doesn't restrict you, but gives you pure freedom of movement? One that positively accentuates your living style? One that matches the sustainable and natural aesthetic of our time? Our GlanPark® 3-layered hardwood flooring offers all that and much more.

The desire for individuality is more pronounced than ever before. Our artisanal hardwood flooring allows you to live and experience this individuality in any situation and in any style. You don't have to conform - your new hardwood floor adapts to your wishes, uncompromisingly and unmistakably.

With your desired combination of flooring, you create the basis for many satisfied years with a hardwood floor that fits you perfectly. It is timeless, full of character, and gives you a new quality of life.

EACH PLANK IS REFINED ACCORDING TO YOUR WISHES.



In our Lüneburg workshop, each individual plank of your new 3-layered hardwood flooring undergoes artisanal production processes. Only when you have decided on the final combination of your desired flooring, do our employees begin the production process.

Using selected techniques and high-quality raw materials, we customize and refine the flooring in our workshop. This is done exclusively with environmentally safe oils and stains from Rubio® Monocoat. Our employees work meticulously and with particular dedication for the lively material of wood, turning each individual plank into a fitting part of a larger whole - your dream hardwood floor.



Rubio® MONOCOAT



3-LAYERED PARQUET 2G



3-layered-parquet 2G | markant sorting | raw parquet

3-layered hardwood flooring 2G

1900/2200 mm | 1 butt-jointed plank per package
approx. 14/15 mm | **top layer approx. 3-4 mm** (10% tolerance)
middle layer approx. 9 mm | counteracting approx. 2 mm (poplar wood)
Wood moisture content 8 % (+/- 1 %) | 4-sided micro bevel | 2G DropDown click system

HxBxL 14/3 x 190 x 1900 mm

Available assortments: elegant, natural, markant and rustic

HxBxL 15/4 x 260 x 2200 mm*

Available assortments: natural and markant

**Discontinued item | While stocks last*

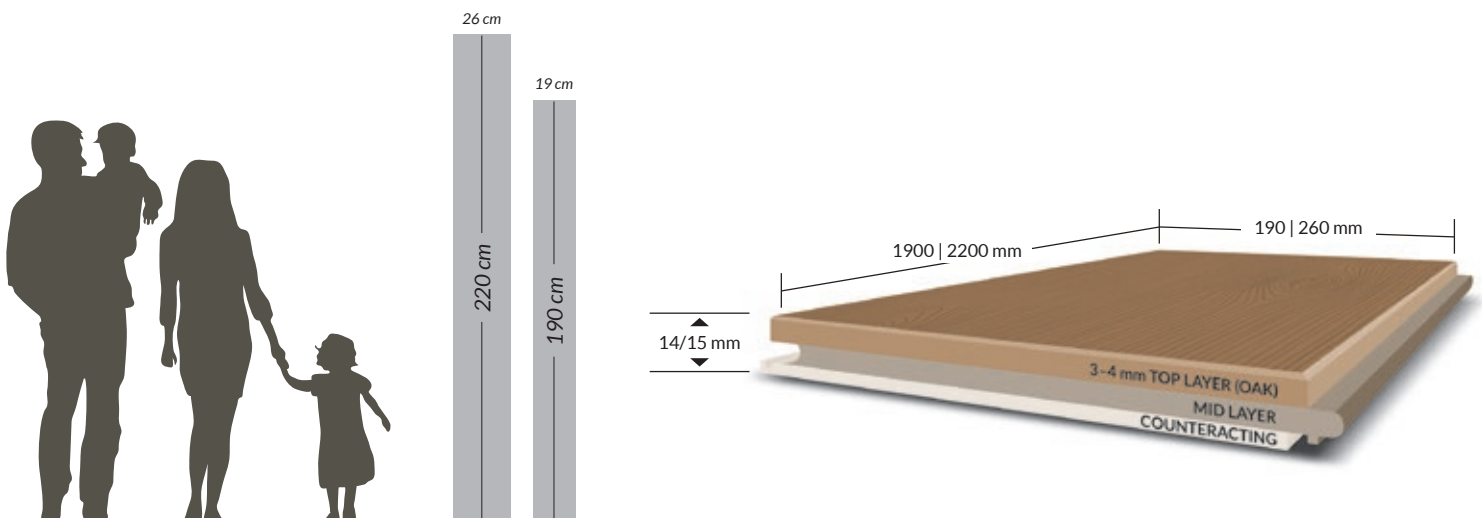

Thickness approx. 14/15 mm

While supplies last Shorter lengths are available upon request. Due to the different formats, deviations between the ordered and final products may occur. This slight material overage is a maximum of 3% and will be charged. Herringbone and Hungarian pattern are delivered in the dimensions specified above with left and right slats.



**5 YEARS
WARRANTY**



**SUITABLE FOR
UNDERFLOOR
HEATING**



3-LAYERED PARQUET 2G

hand-scraped

3-layered-parquet 2G | markant sorting | hand-scraped | raw parquet

3-layered hardwood flooring 2G handgehobelt

1900/2200 mm | 1 butt-jointed plank per package
approx. 14/15 mm | **top layer approx. 3-4 mm** (10% tolerance)
middle layer approx. 9 mm | counteracting approx. (poplar wood)
Wood moisture content 8 % (+/-1 %) | 4-sided micro bevel | 2G DropDown click system

Available assortments: markant

HxBxL 14/3 x 190 x 1900 mm*

HxBxL 15/4 x 260 x 2200 mm*

**Discontinued item | While stocks last*



What does „hand-scraped“ mean?

The unique surface is achieved through mechanical processing with pressure and heat. Gentle waves in the longitudinal direction give the floor a natural texture and provide a pleasant and authentic feeling underfoot.

This turns the surface of each hardwood plank into a genuine unique piece.



SURFACE VIEW OF SORTINGS

3-layered hardwood flooring 2G | Raw material without surface treatment

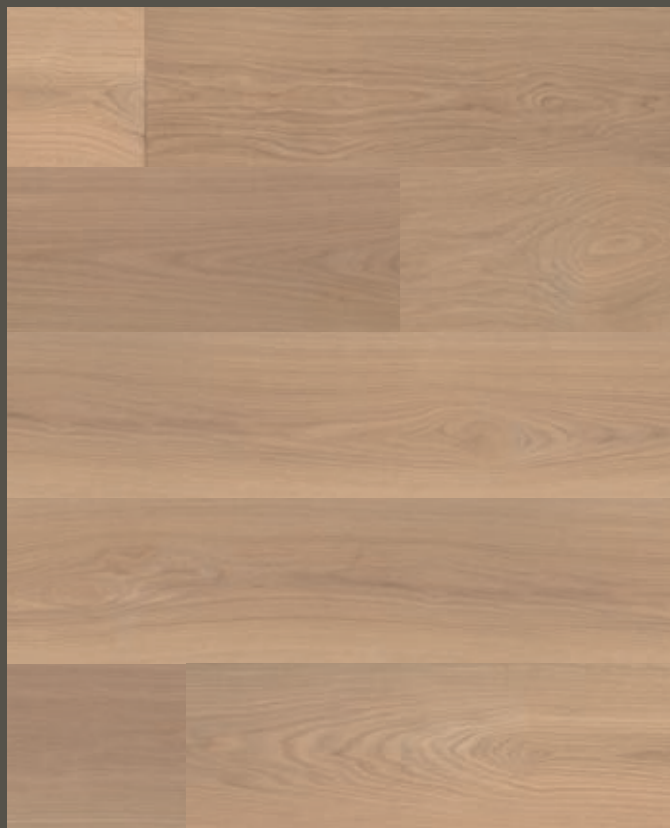

Elegant



Natural

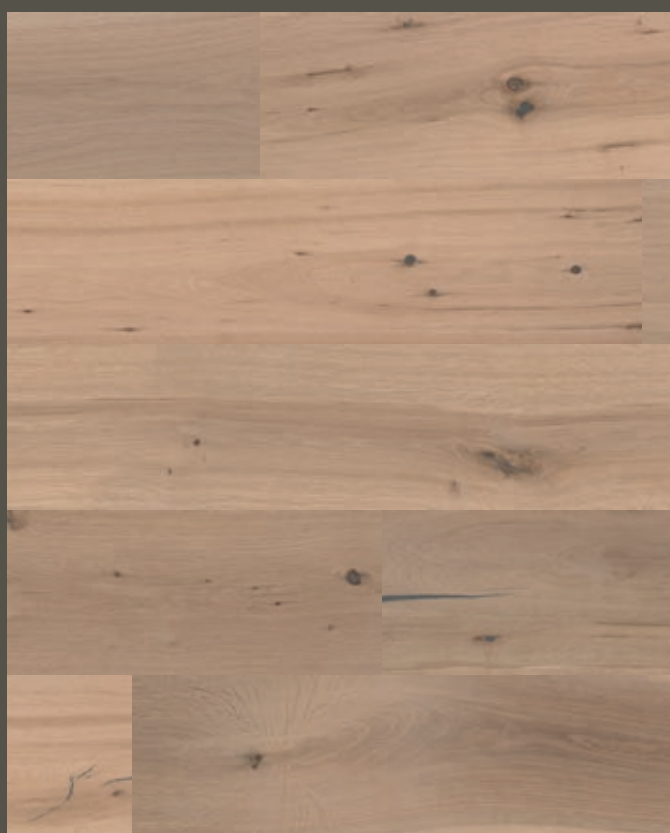

Markant



Rustic

WHAT MEANS „2G“ AND „5G-C“?

Difference between installation systems

„**5G Valinge**“ is an installation system developed by the Swedish company Valinge. It is a click system in which the planks are simply locked together. This is done by snapping the tongue into the groove. The system is very easy to install and does not require any additional tools.

Das „**2G Dropdown**“-system is a different installation system in which the planks are also locked together. Here, the tongue is pressed into the groove until the two planks are level. The system requires a bit more force than the „5G Valinge“ system, but is still relatively easy to install.

Both systems are very effective and can be installed quickly and easily. The choice between the two systems often depends on personal preferences (installer experience), as well as the specific requirements of the project (product availability).





3-LAYER STRIP PARQUET

French herringbone pattern

3-layer strip parquet Chevron

Approx. 14 mm | approx. **3,4 mm top layer** (european oak) | middle layer approx. 8,6 mm | counter-pull approx. 2 mm (spruce)
sanded with 120er grit | beveled on all sides | tongue and groove

HxBxL **14 x 128 x 547 mm**

HxBxL **14 x 128 x 710 mm**

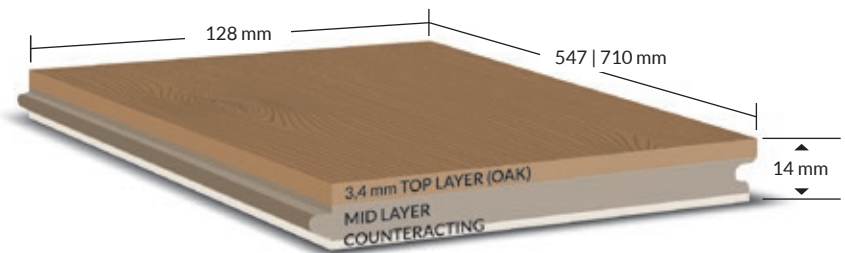

SURFACE VIEW OF SORTINGS

3-layer strip parquet Chevron French herringbone pattern | Raw material without surface treatment

Elegant/natural

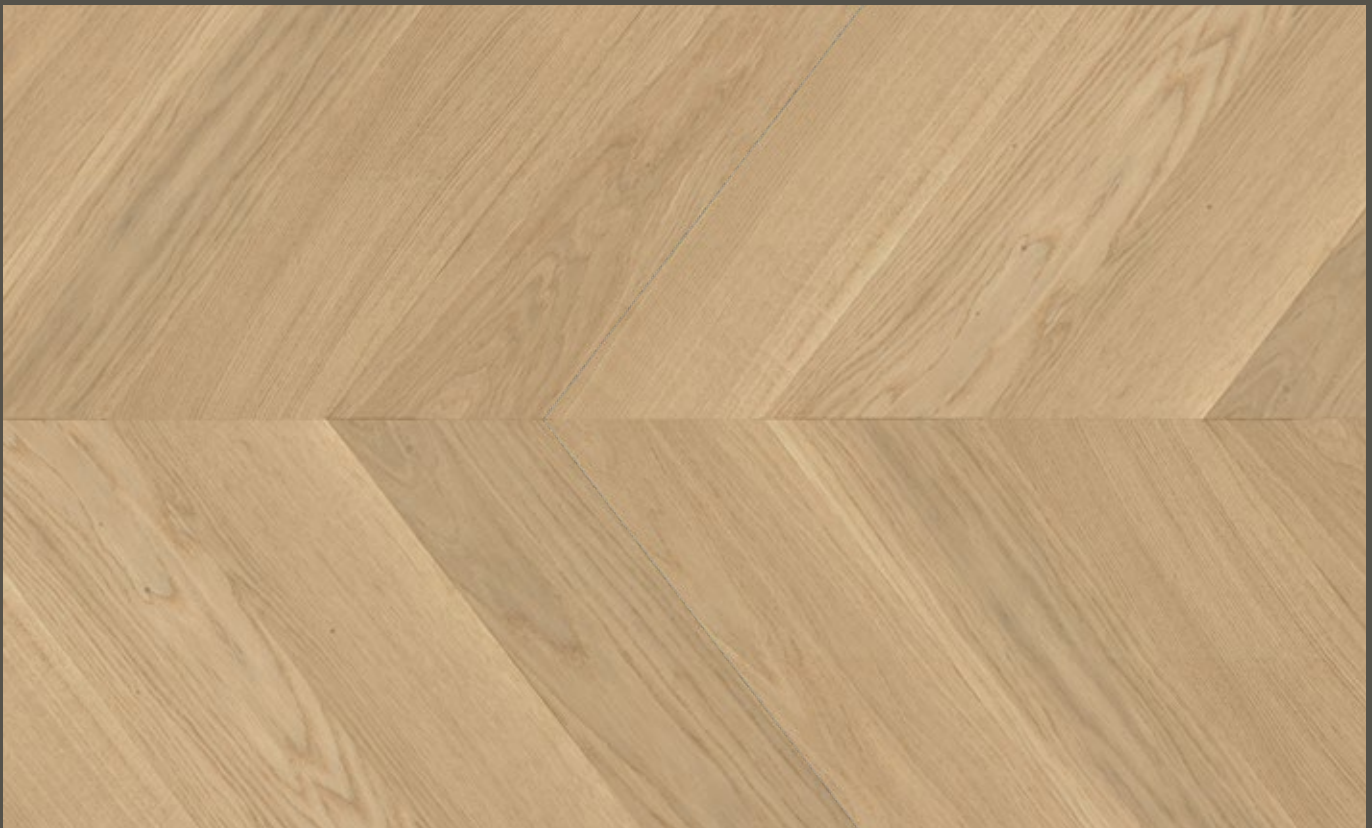

CHEVRON

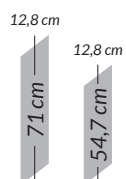

Herringbone and Hungarian pattern are supplied in the above dimensions with left and right elements.

Thickness approx. 14 mm



Rustic

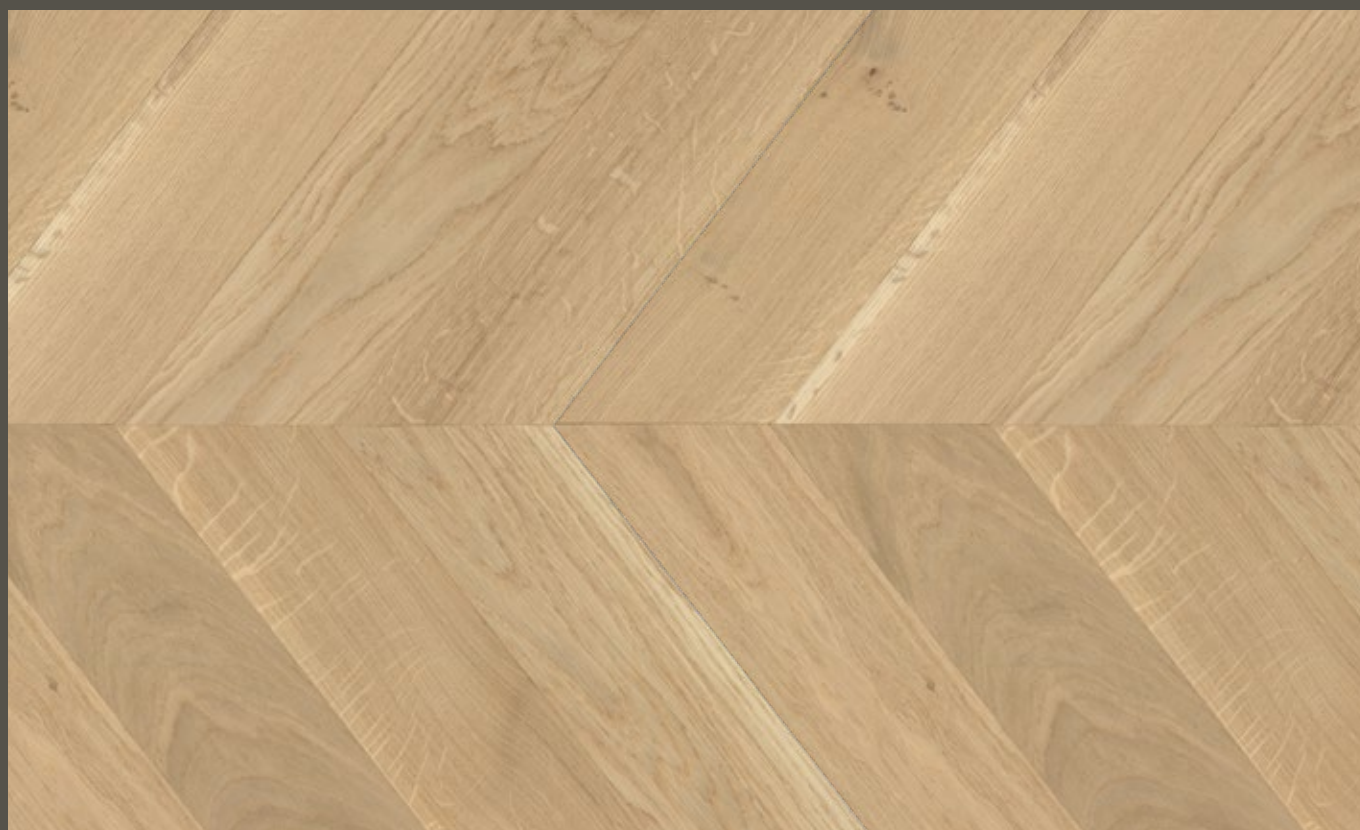



3-LAYERED PARQUET 5G-C

3-layered-parquet 5G-C | elegant sorting | raw parquet

3-layered hardwood flooring 5G-C

1900/2200 mm | 1 butt-jointed plank per package
approx. 14 mm | ca. **3 mm top layer** (10% tolerance) | middle layer approx. 9 mm | counter-pull approx. 2 mm (poplar wood)
Wood moisture content 8% (+/-1%) | 4-sided micro bevel | Välinge 5G-C click connection

Available assortments: elegant, natural, markant and rustic

HxBxL 14/3 x 190 x 1900 mm

HxBxL 14/3 x 260 x 2200 mm

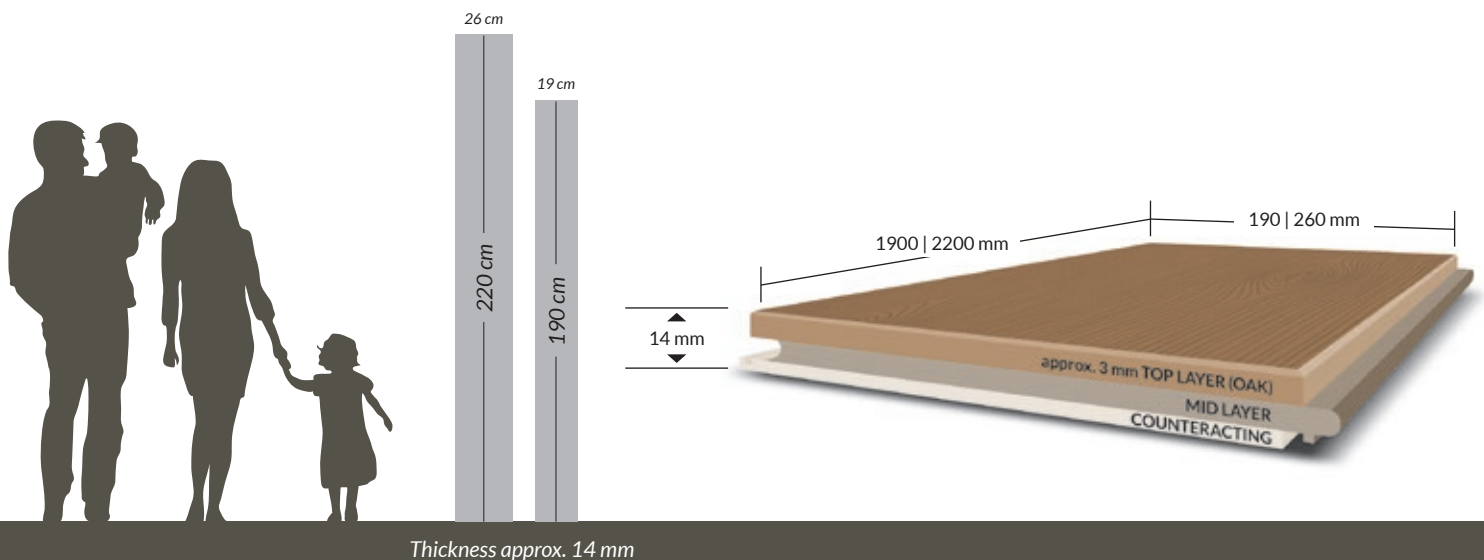

Thickness approx. 14 mm

While supplies last Shorter lengths are available upon request. Due to the different formats, deviations between the ordered and final products may occur. This slight material overage is a maximum of 3% and will be charged. Herringbone and Hungarian pattern are delivered in the dimensions specified above with left and right slats.



**5 YEARS
WARRANTY**



**SUITABLE FOR
UNDERFLOOR
HEATING**

SURFACE VIEW OF SORTINGS

3-layered hardwood flooring 5G-C | Raw material without surface treatment

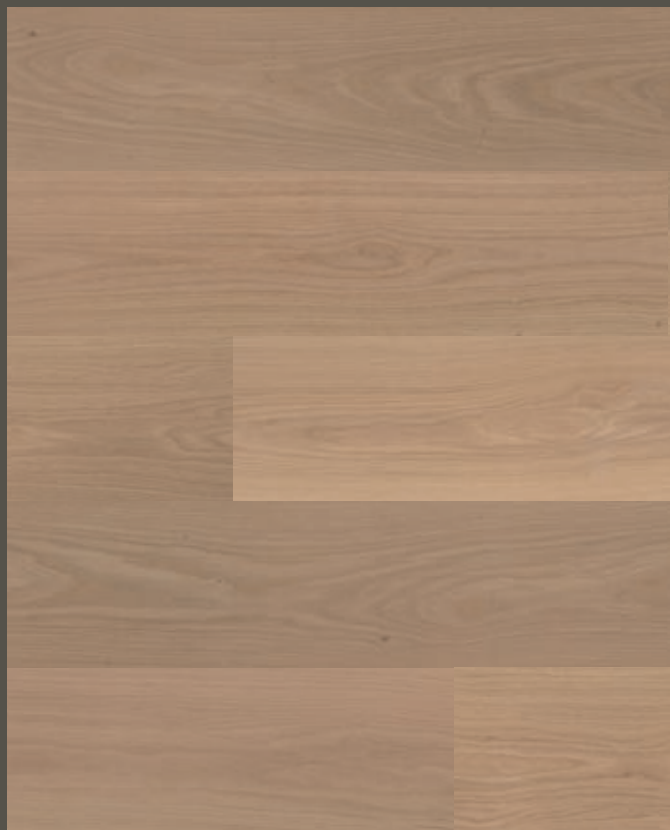

Elegant



Natural



Markant

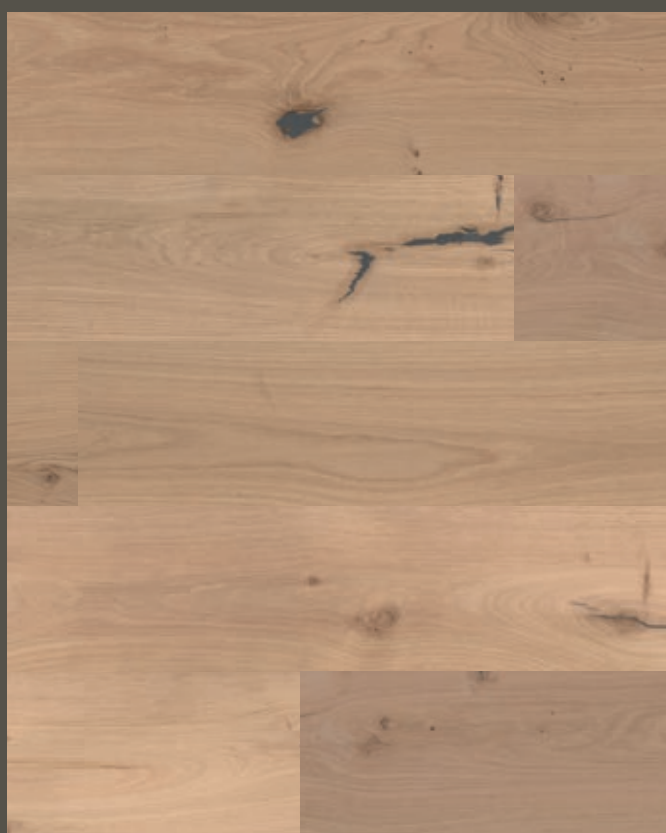

Rustic



STAIR EDGES

3-layer parquet block steps | angled steps



Stair image for illustration purposes only

BLOCK STEP sanded/spackled

Dimensions: 40 x 1800 mm | Tread: 25 mm | Nose thickness: 40 mm | Riser: 25 mm
14/15 mm | approx. 9 mm spruce/poplar + 3/4 mm oak
counterbalance approx. 2 mm
Välinge 5G-C or DropDown click connection

HxBxL 14/15 x 40 x 1800 mm

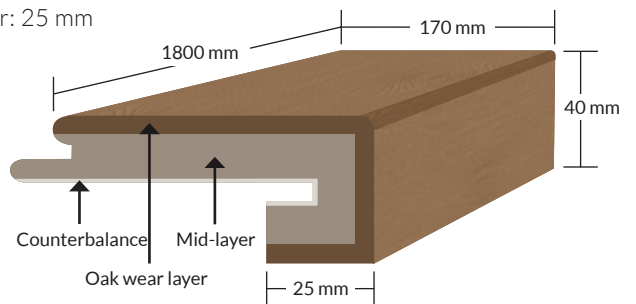

ANGLED STEP sanded/spackled

Dimensions: 250/250 x 1800 mm
14/15 mm | approx. 9 mm spruce/poplar + 3/4 mm oak
counterbalance approx. 2 mm
Välinge 5G-C or DropDown click connection

HxBxL 14/15 x 210/210 x 1800 mm

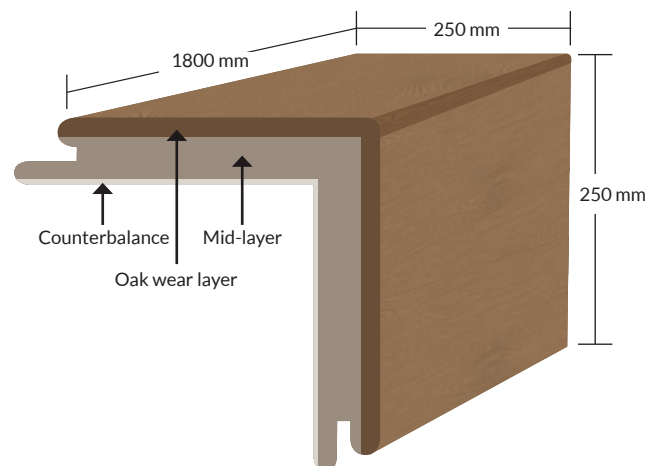

5 YEARS
WARRANTY

ROUGH WOOD LOOK

Natural style for your parquet

Rubio MONOCOAT

Rubio MONOCOAT® Invisible Protector preserves the natural appearance and structure of your wood. The surface is permanently protected and acquires a rough wood effect.

The Rubio® Invisible Protector is based 100 % on plant-based resins. Even on deeply brushed parquet floors, a natural rough wood look can be achieved.



FOUR SORTINGS

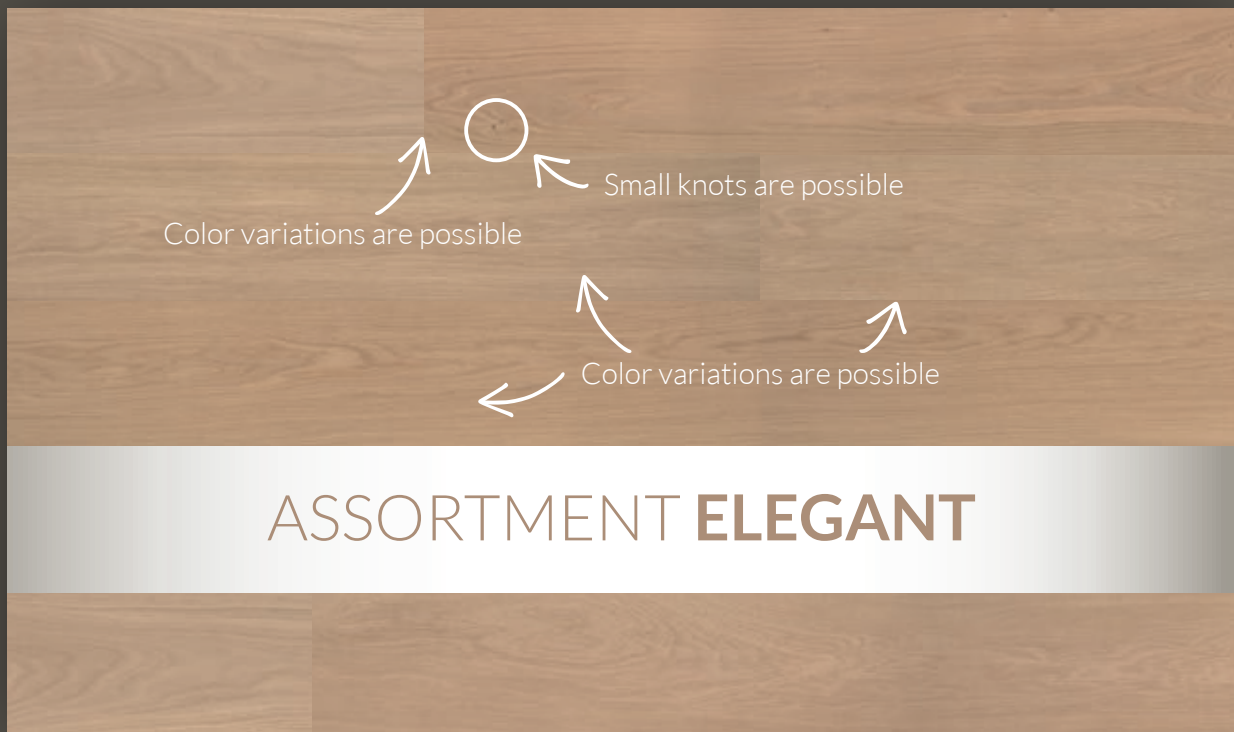

Illustrations: raw material without surface treatment

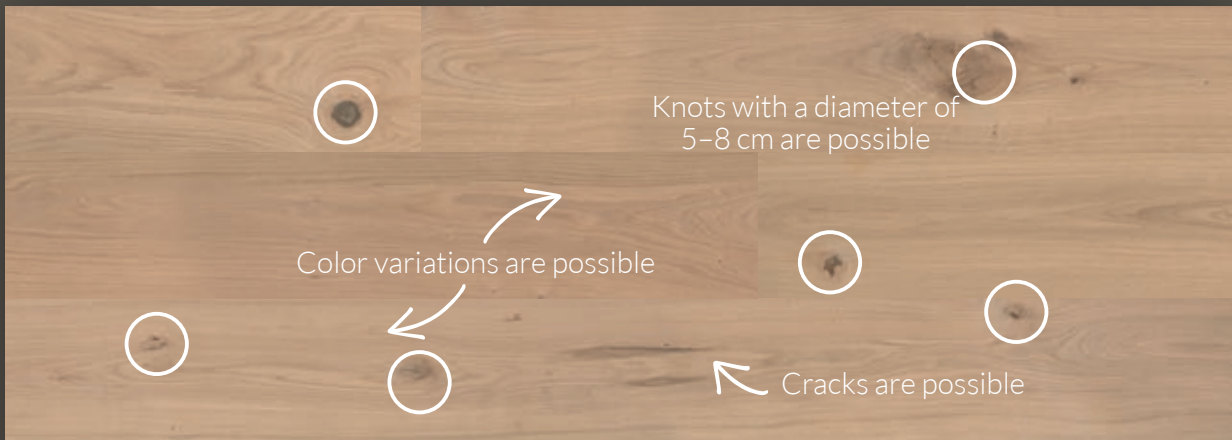

ASSORTMENT **MARKANT**

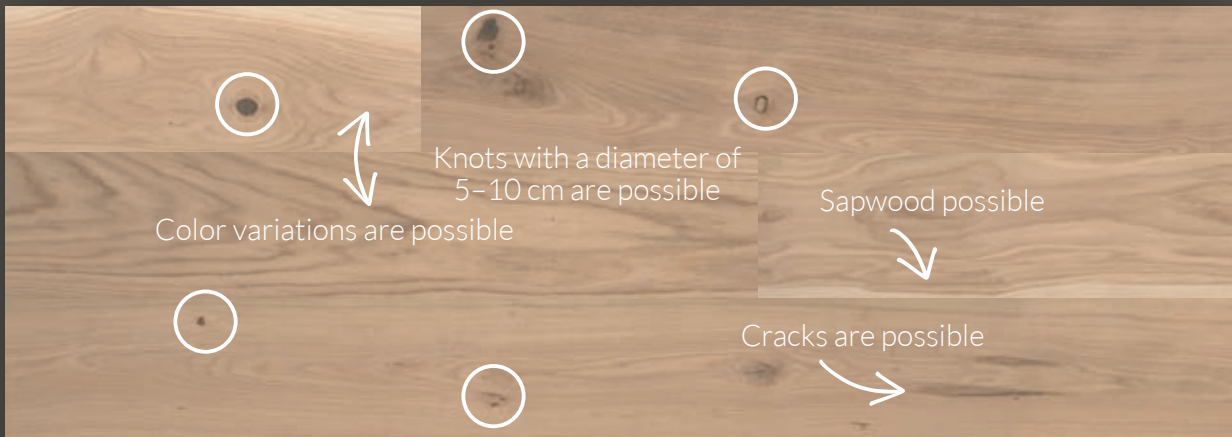

ASSORTMENT **RUSTIC**



Wood is a natural product - variations from the sorting guidelines listed may occur and do not constitute a defect.





! Wood is a natural product - variations from the sorting guidelines listed may occur and do not constitute a defect.



Installation example: Elegant sorting | White colored oil



Wood is a natural product - variations from the sorting guidelines listed may occur and do not constitute a defect.



Installation example: Natural sorting | Walnut colored oil



! Wood is a natural product - variations from the sorting guidelines listed may occur and do not constitute a defect.

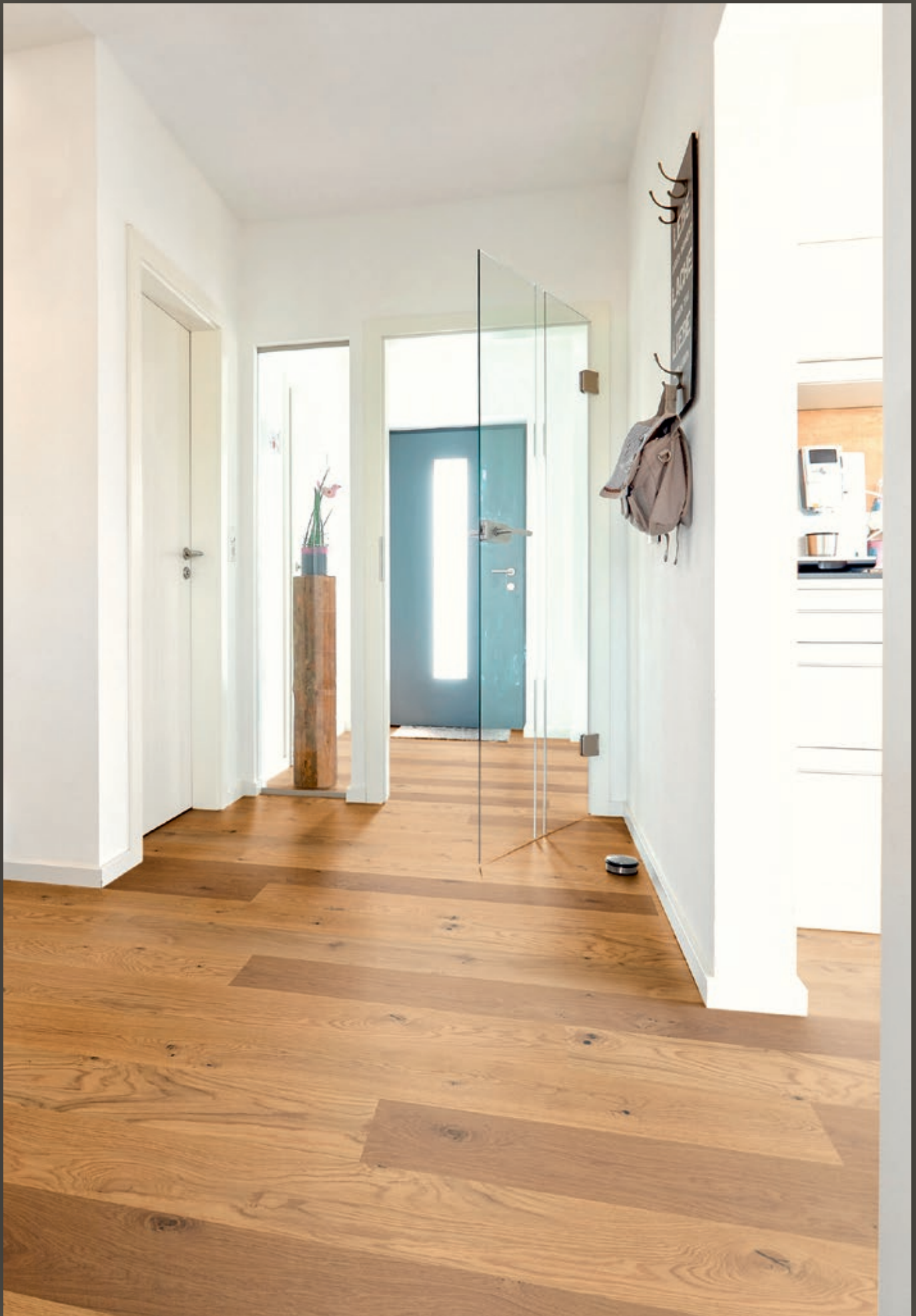

Installation example: Markant sorting | Pine colored oil



Wood is a natural product - variations from the sorting guidelines listed may occur and do not constitute a defect.



Installation example: Rustic sorting | Black colored oil

SIX SURFACES



FINE
SANDED.



LIGHTLY
BRUSHED.



MEDIUM
BRUSHED.



HEAVILY
BRUSHED.



OPTIK
HAND-PLANED SURFACE.

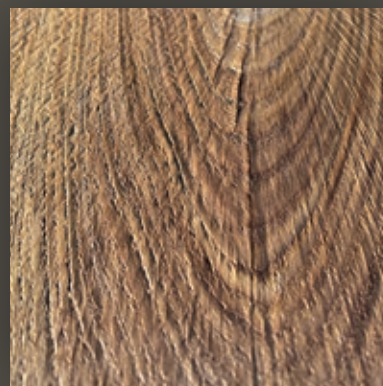

OPTIK
SAWN SURFACE.

The refreshing liveliness of the parquet is achieved through the surface you choose. Not only does it vary the appearance of the floor, but also the feeling that accompanies you with every step on it. The respective character is created by brushing with wire or nylon brushes. This highlights and emphasizes the grain patterns of individual woods. The individual processing makes each plank a unique piece.



TWELVE EFFECTS



Fumed Intense



Fumed Pure



Fumed Light



Smoke Intense



Smoke Pure



Smoke Light



Authentic 1



Authentic 2



Authentic 3



Authentic 4



Authentic 5



Authentic 6

The colors shown were applied to oak wood. The colors shown are indicative and not binding.

Rubio MONOCOAT

At GlanPark®-Parquet, we offer you versatile effects that give your desired floor its own unique character. By choosing a particular effect, you can skillfully adapt your parquet floor to your style and the ambiance of your living spaces, such as by selecting a smoking or aging effect. Here alone, you will find six different shades. Aging effects are also a selected means of giving the floor a lot of liveliness. We achieve these special effects through the use of a non-reactive pre-stain, which is applied simply and without overlap in our factory.



FORTY + 2 COLOURS



Antique Bronze



Aqua



Ash Grey



Biscuit



Black



Bourbon



Castle Brown

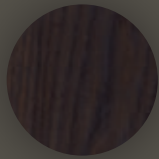

Charcoal



Cherry Coral



Chocolate



Corn silk



Cotton White



Dark Oak



Gris Beige



Havanna



Ice Brown



Mahogany



Mist



Mist 5%



Mud Light



Natural



Oak



Olive



Oyster



Pine



Pure



Savanna



Silver Grey



Sky Grey



Slate Grey



Smoke



Smoke 5%



Smoked Oak



Stone



Super White



Titanium Grey



Vanilla



Walnut



White



White 5%



Crudo



Optics raw wood

The colors shown were applied to oak wood. The colors shown are indicative and not binding.

Rubio MONOCOAT

Trust your intuition and imagination when choosing the color tone. Colors are perceived individually and can be felt much better than defined. And a color that will surround and accompany you for many years over a large area should match your furnishings, style, and personal taste. Forty standard colors for GlanPark®-Parquet provide you with sufficient flexibility and decision-making space.



THIRTEEN COLOR TRENDS



Cinnamon Brown

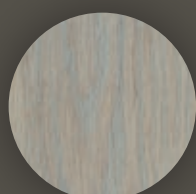

Nordic Blue

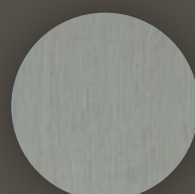

Morning Mist



Velvet Green



Touch of Gold



Peacock Green

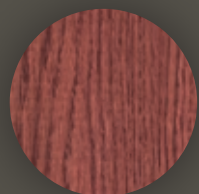

Rusty Brown



Midnight Indigo

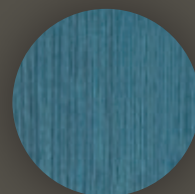

Teal Blue

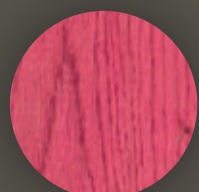

Pomegranate Pink



Winter Blush

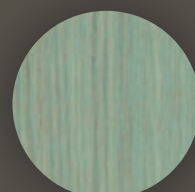

Frost Green

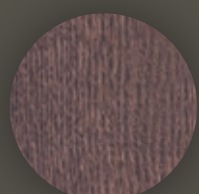

Heather Purple

Rubio MONOCOAT

The colors shown were applied to oak wood. The colors shown are indicative and not binding.

For stronger contrasts, more colorfulness and greater creative freedom when composing your GlanPark®-Parquet, you also have thirteen vibrant color trends at your disposal. This creates even more expressiveness and creativity in your flooring. The enormous variety of variations is made possible by the combination of previous effect treatment and final oil treatment.

A brand of
LPM GmbH

Zeppelinstraße 3
21337 Lüneburg

T +49 (0)4131 9276999

F +49 (0)4131 9276998

M info@glanpark.de

www.glanpark.de

 [@glanpark.parkett](https://www.facebook.com/glanpark.parkett)

 [@glanpark_parkett](https://www.instagram.com/glanpark_parkett)